



栅极驱动光耦
Gate Drive Optocoupler

QX343

宁波群芯微电子股份有限公司
NINGBO QUNXIN MICROELECTRONICS CO., LTD.

中国 浙江省宁波杭州湾新区玉海东路 68 号
68 Yuhaidong Road, Hangzhou Bay New District, Ningbo, Zhejiang, China

概述 Description

QX343 包含一个砷化铝镓 LED，它被光学耦合到一个具有功率输出级的集成电路上。该光电耦合器非常适合驱动电机控制逆变器应用中使用的功率 IGBT 和 MOSFET。输出级的高工作电压范围提供了栅极控制装置所需的驱动电压。该光电耦合器提供的电压和高峰值输出电流使其非常适合直接驱动额定功率高达 1200V/200A 的 IGBT。

The QX343 contains an AlGaAs LED, which is optically coupled to an integrated circuit with a power output stage. This optocoupler is ideally suited for driving power IGBTs and MOSFETs used in motor control inverter applications. The high operating voltage range of the output stage provides the drive voltages required by gate controlled devices. The voltage and high peak output current supplied by this optocoupler make it ideally suited for direct driving IGBT with ratings up to 1200 V / 200 A.

特性 Features

- 最大峰值输出电流：4.0A
Maximum peak output current: 4.0A
- 最小峰值输出电流：3.0A
Minimum peak output current: 3.0A
- 轨道对轨道输出电压
Rail-to-Rail output voltage
- 最大传播延迟：200ns
Maximum propagation delay: 200ns
- 最大传播延迟差：100ns
Maximum propagation delay difference: 100ns
- 带迟滞的 LED 输入电流
The LED input current with hysteresis
- 符合加强绝缘标准
Meet reinforced insulation standards

应用 Applications

- 开关电源
Switching power supplies
- IGBT/MOSFET 栅极驱动器
IGBT/MOSFET gate drive
- 交流和无刷直流电机驱动器
AC and Brushless DC motor drives
- 可再生能源逆变器
Renewable energy inverters
- 工业逆变器
Industrial inverters

真值表 Truth table

LED	VCC-VEE " POSITIVE GOING" (TURN-ON)	VCC-VEE "NEGATIVE GOING" (TURN-OFF)	VO
OFF	0~30V	0~30V	LOW
ON	0~12.1V	0~11.1V	LOW
ON	12.1~13.5V	11.1~12.4V	TRANSITION
ON	13.5~30V	12.4~30V	HIGH

封装和原理图 Package and Schematic Diagram

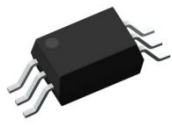

SOP6-W

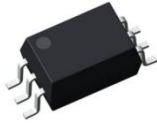

SOP6-P

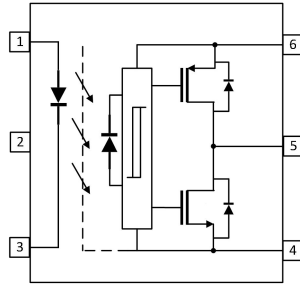

Pin Configuration

- 1. Anode
- 2. NC
- 3. Cathode
- 4. VSS
- 5. VO
- 6. VDD

注：必须在引脚 4 和引脚 6 之间连接 1 个 μF 的旁路电容。

Note: $1\mu\text{F}$ bypass capacitor must be connected between Pin 4 and 6.

产品型号命名规则 Order Code

QX 343 - UN Y - W (V) (ZZ)

- ①
- ②
- ③
- ④
- ⑤
- ⑥
- ⑦

① 公司代码 Company Code (QX: 群芯 Qunxin)

② 产品系列 Product Series (343)

③ 框架类型 Lead Frame (Cu: 铜框架 Copper)

④ 树脂类型 Epoxy Type (H: 无卤 Halogen-free)

⑤ 封装形式 Package (P: PSOP; W: WSOP)

⑥ 器件工作温度范围 Device Operating Temperature Range (特殊范围需填或者空白 Special Range need to be filled in or left blank)

⑦ 内部补充代码 Internal Supplementary Code (数字或者空白 Number or None)

印字信息 Marking Information

- 印字中“”为群芯品牌 LOGO
“”denotes LOGO
- 印字中“Y”代表年份: A(2018), B(2019), C(2020).....
“Y”denotes YEAR: A(2018), B(2019), C(2020).....
- 印字中“WW”代表周号
“WW”denotes Week’s number
- 印字中“N”代表星期几
“N”denotes the day of the week
- 印字中的“H”代表无卤
“H”denotes Halogen-free

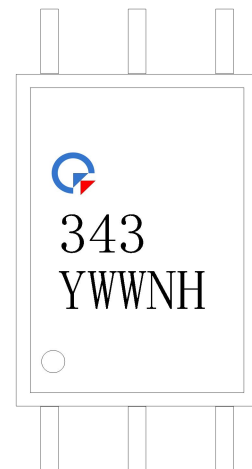

绝缘和安规信息 Insulation and Safety related specifications

项目 Item	符号 Symbol	数值 Value	单位 Unit	备注 Note
爬电距离 Creepage Distance	L	≥7	mm	从输入端到输出端，沿本体最短距离路径 Measured from input terminals to output terminals, shortest distance path along body.
电气间隙 Clearance Distance	L	≥7	mm	从输入端到输出端，通过空气的最短距离 Measured from input terminals to output terminals, shortest distance through air.
绝缘距离 Insulation Thickness	DTI	≥0.4	mm	发射器和探测器之间的绝缘厚度 Insulation thickness between emitter and detector.
峰值隔离电压 Peak Isolation Voltage	V_{IORM}	1500	V_{peak}	DIN/EN/IEC EN60747-5-5.
瞬态隔离电压 Transient Isolation Voltage	V_{IOTM}	7000	V_{peak}	DIN/EN/IEC EN60747-5-5.
隔离电压 Isolation Voltage	V_{ISO}	5000	V_{rms}	For 1 min

极限参数 Absolute Maximum Ratings ($T_A=25^{\circ}C$)

参数 Parameter		符号 Symbol	额定值 Rating	单位 Unit
输入 Input	平均输入电流 Average Input Current	$I_{F(AVG)}$	25	mA
	峰值瞬态输入电流 (<1 μs 脉冲宽度, 300 pps) Peak Transient Input Current (<1 μs Pulse Width, 300 pps)	$I_{F(TRAN)}$	1.0	A
	反向电压 Reverse Voltage	V_R	5	V
输出 Output	高峰值输出电流 High Peak Output Current	$I_{OH(PEAK)}$	-4	A
	低峰值输出电流 Low Peak Output Current	$I_{OL(PEAK)}$	4	A
	电源电压 Supply Voltage	$V_{CC}-V_{EE}$	0~35	V
	峰值输出电压 Peak Output Voltage	$V_{O(PECK)}$	-0.5~ V_{CC}	V
	降额因子(在 $T_A=85^{\circ}C$ 以上) Rating Factor (Above $T_A=85^{\circ}C$)	P_{DD}	16.9	mW/°C
	输出功率 Power Dissipation	P_O	700	mW
总功耗 Total Power Dissipation		P_{tot}	745	mW
降额因子 (在 $T_A=85^{\circ}C$ 以上, 总功耗) Rating Factor (Above $T_A=85^{\circ}C$, Total Power Consumption)		P_{ODD}	15.3	mW/°C
隔离电压 Isolation Voltage		V_{ISO}	5000	V_{rms}
工作温度 Operating Temperature		T_{opr}	-40~+105	°C
储存温度 Storage Temperature		T_{STG}	-55~+125	°C

参数 Parameter	符号 Symbol	额定值 Rating	单位 Unit
焊接温度 Soldering Temperature	T_{sol}	260	°C

推荐操作条件 Recommended Operating Conditions

参数 Parameter	符号 Symbol	最小值 Min	最大值 Max.	单位 Unit
电源电压 Power Supply Voltage	$V_{CC}-V_{EE}$	15	30	V
开启电流 Input Current (ON)	$I_{F(ON)}$	7	16	mA
关断电压 Input Voltage (OFF)	$V_{F(OFF)}$	-3.6	0.8	V
工作温度 Operating Temperature	T_A	-40	+105	°C

产品特性参数 Electro-optical Characteristics ($T_A=25^\circ\text{C}$)

除非另有说明，所有典型值均为 $T_A = 25^\circ\text{C}$ ， $V_{CC} - V_{EE} = 30\text{ V}$ ， $V_{EE} = \text{Ground}$ ；所有最小和最大规格均是在推荐操作条件下 ($T_A = -40^\circ\text{C} \sim 105^\circ\text{C}$ ， $I_{F(ON)} = 7\text{ mA} \sim 16\text{ mA}$ ， $V_{F(OFF)} = -3.6\text{ V} \sim 0.8\text{ V}$ ， $V_{EE} = \text{Ground}$ ， $V_{CC} = 15\text{ V} \sim 30\text{ V}$)。Unless otherwise noted, all typical values are at $T_A = 25^\circ\text{C}$ ， $V_{CC} - V_{EE} = 30\text{ V}$ ， $V_{EE} = \text{Ground}$ ；all minimum and maximum specifications are at recommended operating conditions ($T_A = -40\text{ to }105^\circ\text{C}$ ， $I_{F(ON)} = 7\text{ to }16\text{ mA}$ ， $V_{F(OFF)} = -3.6\text{ to }0.8\text{ V}$ ， $V_{EE} = \text{Ground}$ ， $V_{CC} = 15\text{ to }30\text{ V}$)。

参数 Parameter	符号 Symbol	条件 Condition	最小 Min.	典型 Typ.	最大 Max.	单位 Unit
输入 Input	正向电压 Forward Voltage	$I_F=10\text{ mA}$	1.2	1.414	1.95	V
	反向电压 Reverse Voltage	$I_R=100\text{ uA}$	5	-	-	V
	阈值电流从低到高 Threshold Input Current Low To High	$R_g=10\Omega$ $C_g=25\text{ nF}, V_O>5\text{ V}$	-	2.8	4.0	mA
	阈值电压从高到低 Threshold Input Voltage High To Low	$R_g=10\Omega$ $C_g=25\text{ nF}, V_O>5\text{ V}$	0.8	-	-	V
	输入正向电压的温度系数 Temperature Coefficient Of Input Forward Voltage	$I_F=10\text{ mA}$	-	-1.7	-	mV/°C
	输入电容 Input Capacitance	$f=1\text{ MHz}, V_F=0\text{ V}$	-	70	-	pF
输出 Output	高电平输出电流 High Level Output Current	$V_O=V_{CC}-4\text{ V}$	-	-2.8	-1.0	A
		$V_{CC}-V_O\leq 15\text{ V}$	-	-	-3.0	
	低电平输出电流 Low Level Output Current	$V_O=V_{EE}+2.5\text{ V}$	1.0	3.5	-	
		$V_{EE}-V_O\leq 15\text{ V}$	3	-	-	

4.0 Amp Output Current IGBT Gate Drive Optocouple

参数 Parameter	符号 Symbol	条件 Condition	最小 Min.	典型 Typ.	最大 Max.	单位 Unit				
高电平输出电压 High Level Output Voltage	V_{OH}	$I_O = -100mA$	$V_{CC} - 0.3$	$V_{CC} - 0.2$	-	V				
		$I_O = 0mA$ $I_F = 10mA$	-	V_{CC}	-					
低电平输出电压 Low Level Output Voltage	V_{OL}	$I_O = 100mA$	-	0.1	0.2					
高电平电源电流 High Level Power Supply Current	I_{CCH}	$R_G = 10\Omega$, $C_G = 25nF, I_F = 10mA$	-	1.9	3	mA				
低电平电源电流 Low Level Power Supply Current	I_{CCL}	$R_G = 10\Omega$, $C_G = 25nF, V_F = 0V$	-	1.9	3					
高输出晶体管电阻 High Output Transistor Resistance	$R_{DS,OH}$	$I_{OH} = -3.0A$	-	1.4	2.5	Ω				
低输出晶体管电阻 Low Output Transistor Resistance	$R_{DS,OL}$	$I_{OL} = 3.0A$	-	0.6	1.5	Ω				
传输特性 Transfer Characteristics	低电平传输延迟 Propagation Delay Time to Low Output Level	T_{PHL}	50	88	200	ns				
	高电平传输延迟 Propagation Delay Time to High Output Level	T_{PLH}					50	66	200	ns
	脉冲失真 Pulse Width Distortion	P_{WD}								
	传播延迟差 Propagation Delay Difference Between Any Two Parts	$P_{DD}(t_{PHL}-t_{PLH})$	$R_G = 10\Omega$ $C_G = 25nF$ $f = 20kHz$	-100	-	100	ns			
	输出上升时间(10%~90%) Output Rise Time (10% To 90%)	T_R	$R_G = 10\Omega$ $C_G = 25nF$ $f = 20kHz$ Duty Cycle=50%	-	43	-	ns			
	输出下降时间(90%~10%) Output Drop Time (90%~10%)	T_F	$I_F = 7mA$ to 16mA $V_{CC} = 15V$ to 30V	-	40	-	ns			
	低电压锁定阈值 Low-Voltage Lock Threshold	V_{UVLO+}	$V_O > 5V$ $I_F = 10mA$	12.1	12.8	-	V			
		V_{UVLO-}		11.1	11.8	12.4	V			
	低电压锁定阈值迟滞 Low-Voltage Locking Threshold For Hysteresis	U_{VLOHYS}	-	-	1.0	-	V			
	输出高电平共模抑制 Output High Level Common Mode Transient Immunity	$ CM_H $	$T_A = 25^\circ C$ $I_F = 10mA$ $V_{CC} = 30V$	35	50	-	kV/ μs			
	输出低电平共模抑制 Output Low Level Common Mode Transient Immunity	$ CM_L $	$V_{CM} = 1500V$ with split resistors	35	50	-	kV/ μs			
	隔离电阻 Isolation Resistance	R_{ISO}	$V_{I-O} = 500VDC$	5×10^{12}	-	-	Ω			
隔离电容 Isolation Capacitance	C_{ISO}	$F = 1MHz$	-	0.6	-	pF				

典型光电特性曲线 Typical Electro-Optical Characteristics Curves

Fig.1 High Output Rail Voltage vs. Ambient Temperature

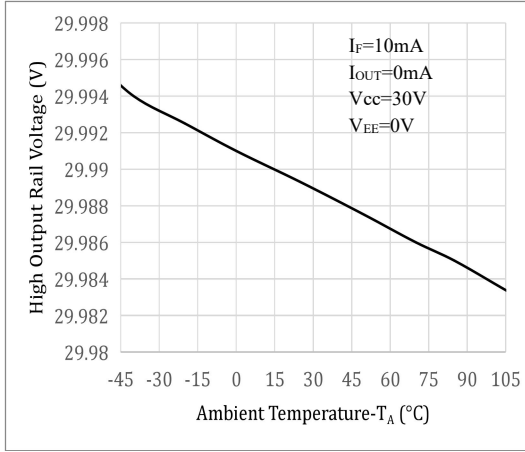

Fig.2 High Level Output Voltage vs. Ambient Temperature

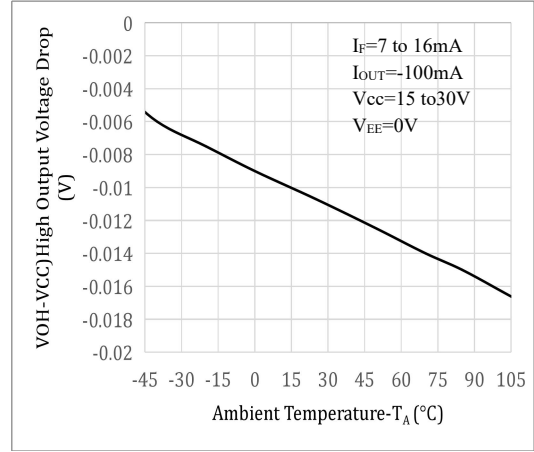

Fig.3 Output Low Voltage vs. Ambient Temperature

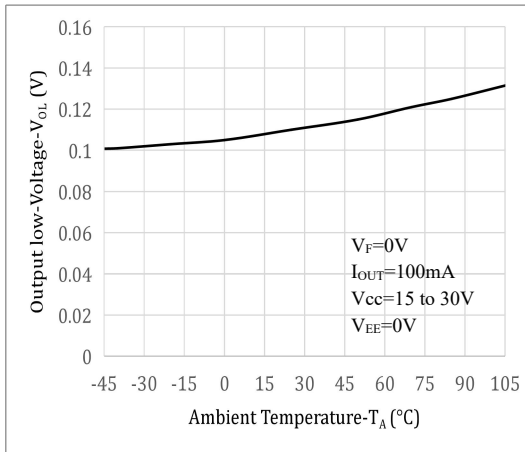

Fig.4 Power Supply Current vs. Ambient Temperature

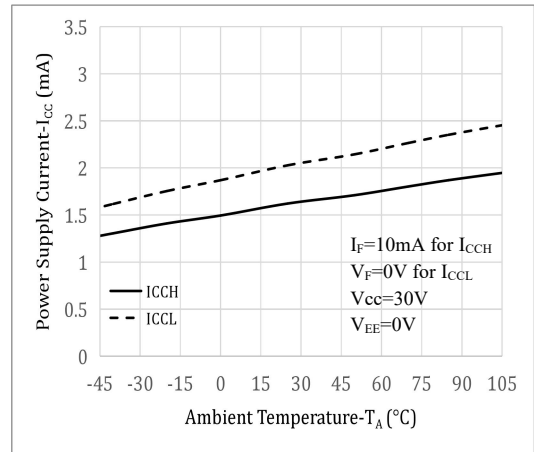

Fig.5 Power Supply Current vs. Supply Voltage

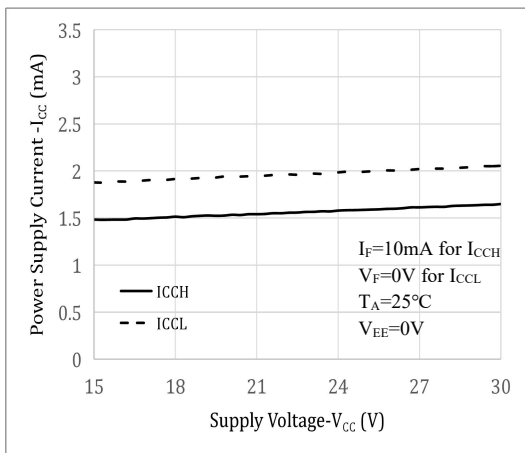

Fig.6 Output Voltage vs. Threshold Input Current Low to High

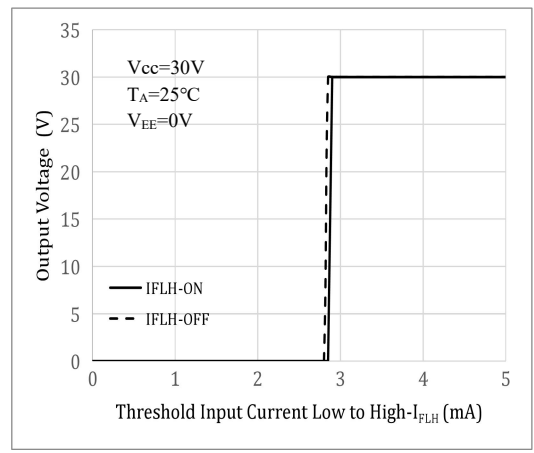

Fig.7 Input Threshold Current vs. Ambient Temperature

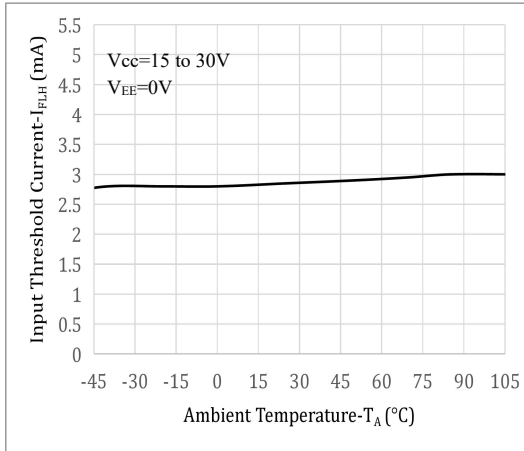

Fig.8 Propagation Delay vs. Power Supply Voltage

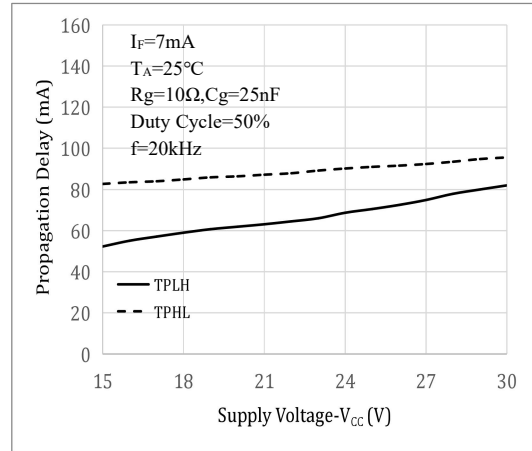

Fig.9 Propagation Delay vs. Forward LED Current

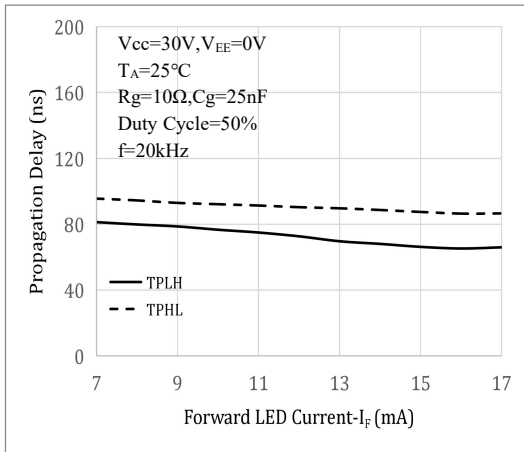

Fig.10 Propagation Delay vs. Ambient Temperature

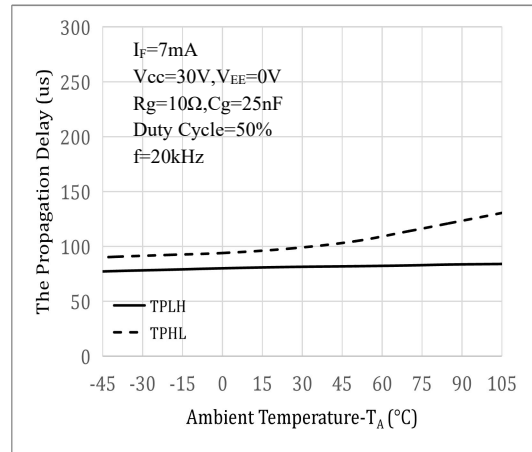
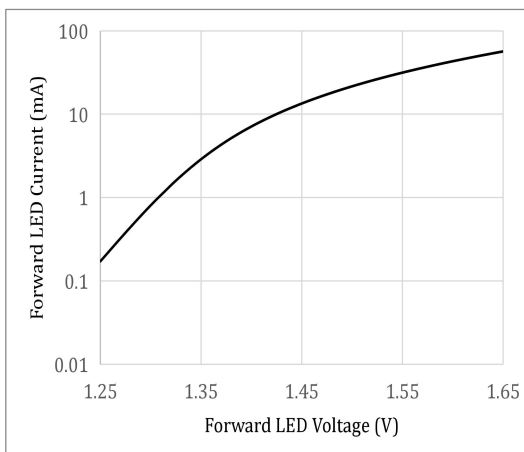

Fig.11 Forward LED Current vs. Forward LED Voltage



测试电路 Test Circuits

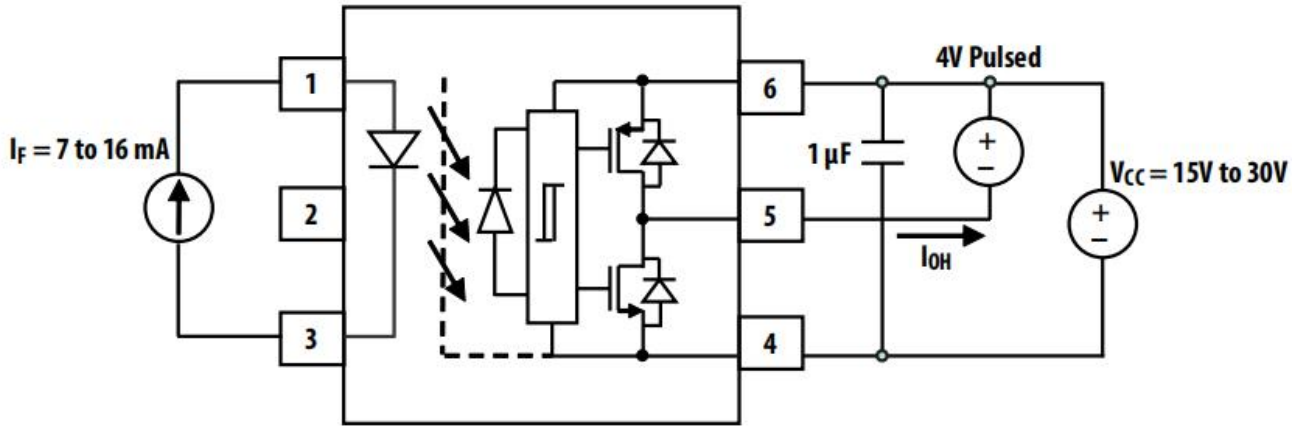

Figure.12 I_{OH} Pulsed Test Circuit

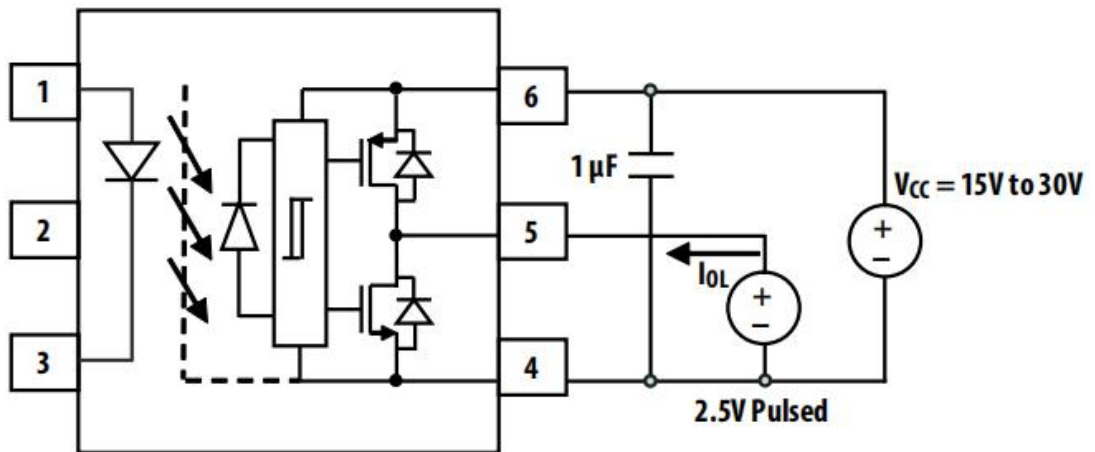

Figure.13 I_{OL} Pulsed Test Circuit

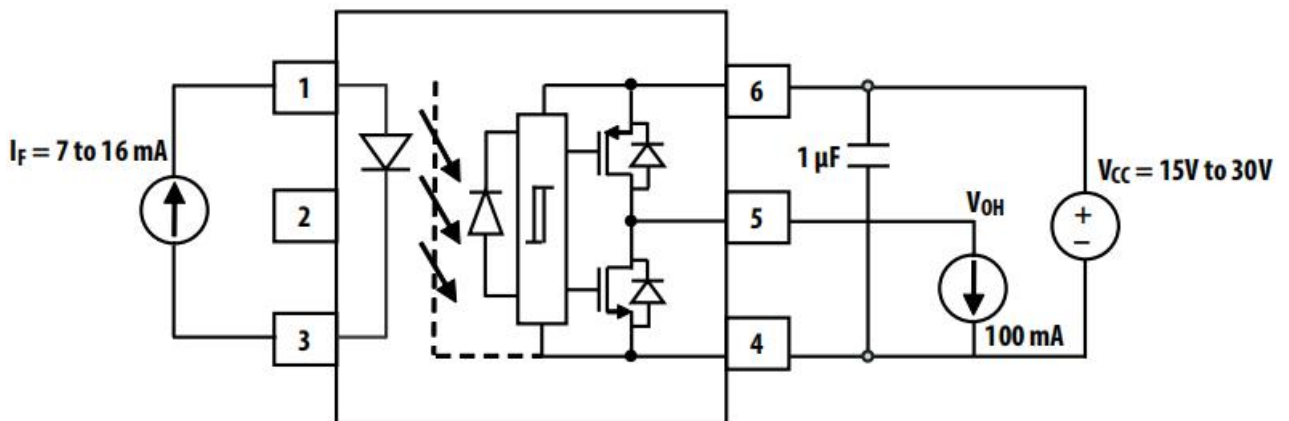

Figure.14 V_{OH} Pulsed Test Circuit

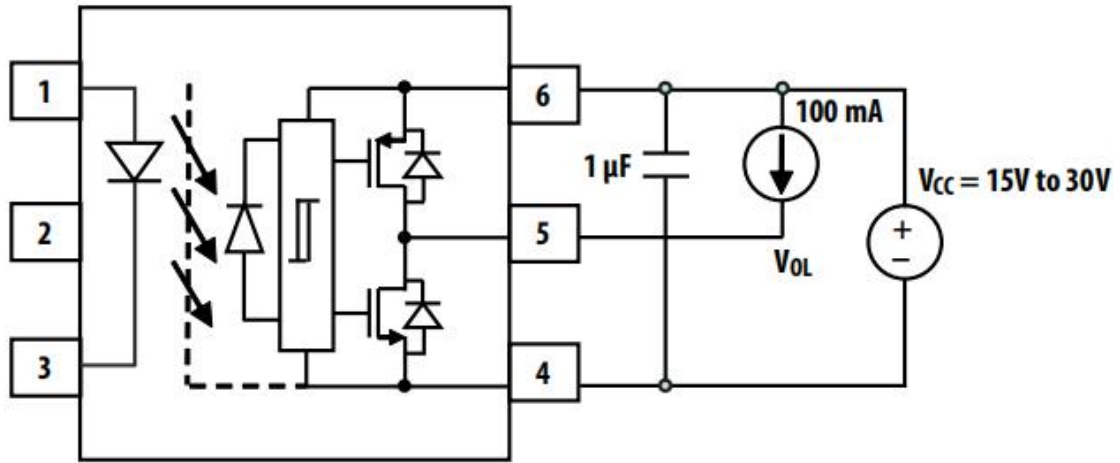

Figure.15 V_{OL} Pulsed Test Circuit

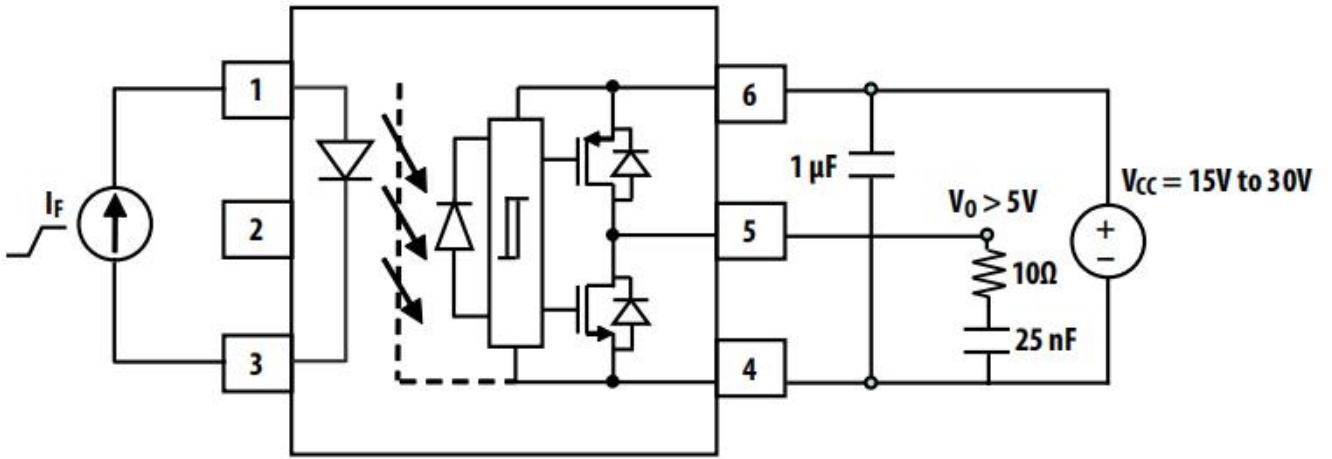

Figure.16 I_{FLH} Test Circuit

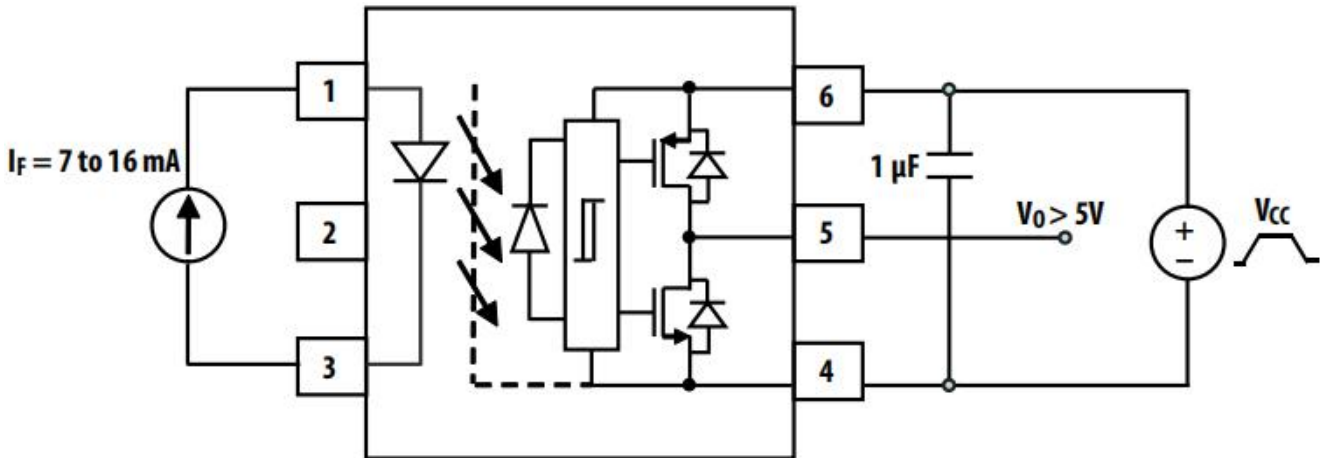

Figure.17 UVLO Test Circuit

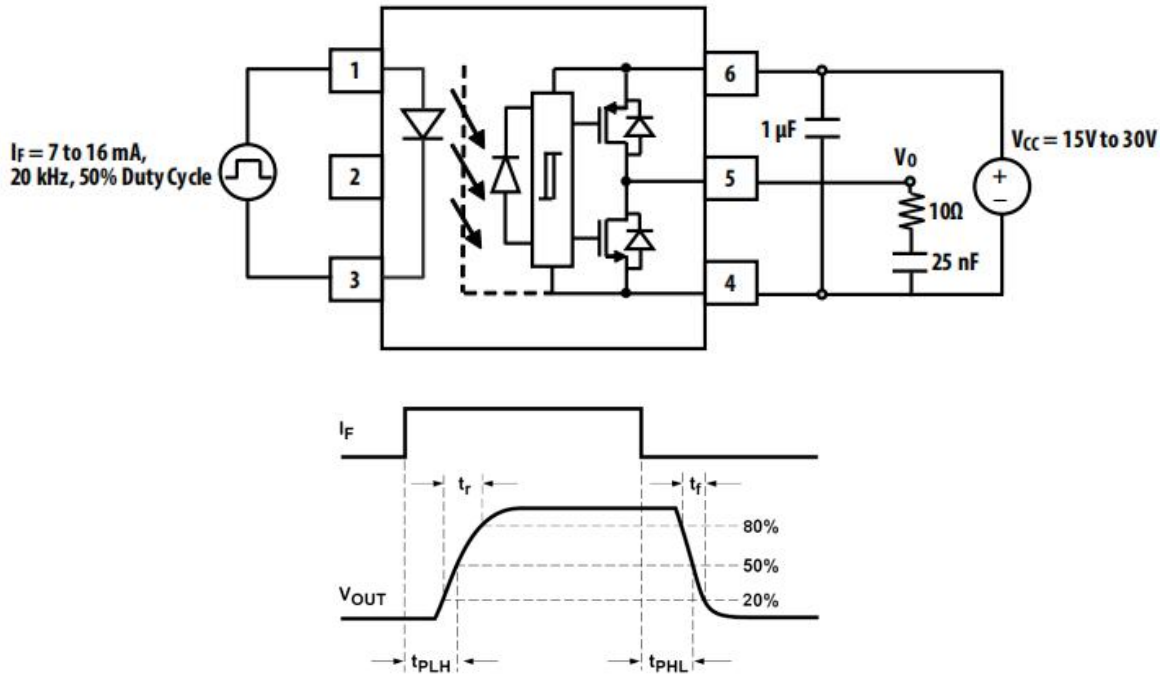

Figure.18 T_{PHL} 、 T_{PLH} 、 T_R 、 T_F Test Circuit

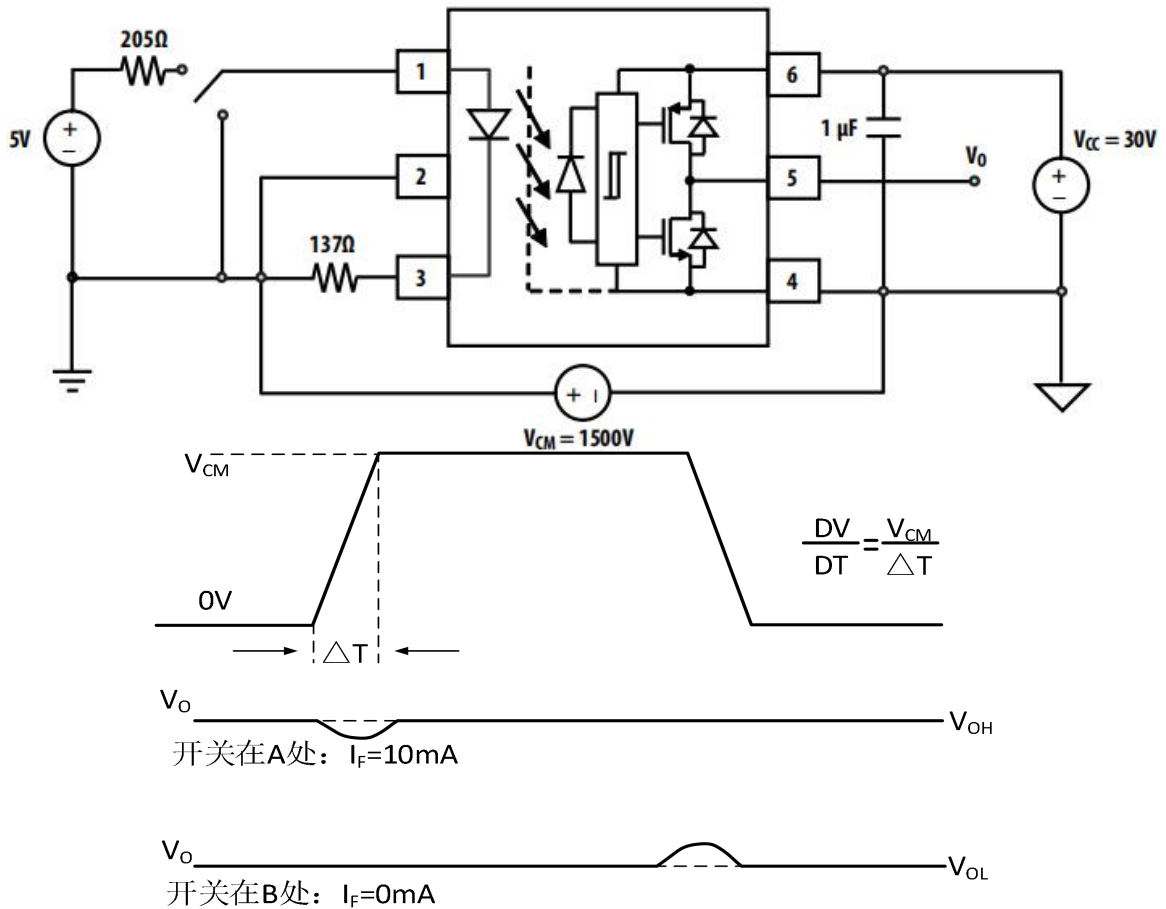
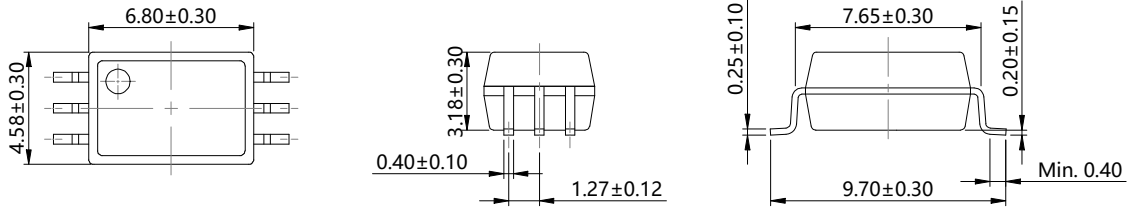

Figure.19 CMR Test Circuit

外形尺寸 Outline Dimensions

SOP6-P



SOP6-W

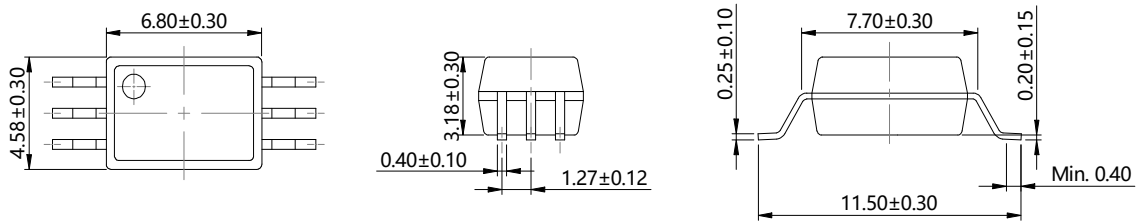

单位 Unit: mm

建议焊盘布局 Recommended Pad Layout

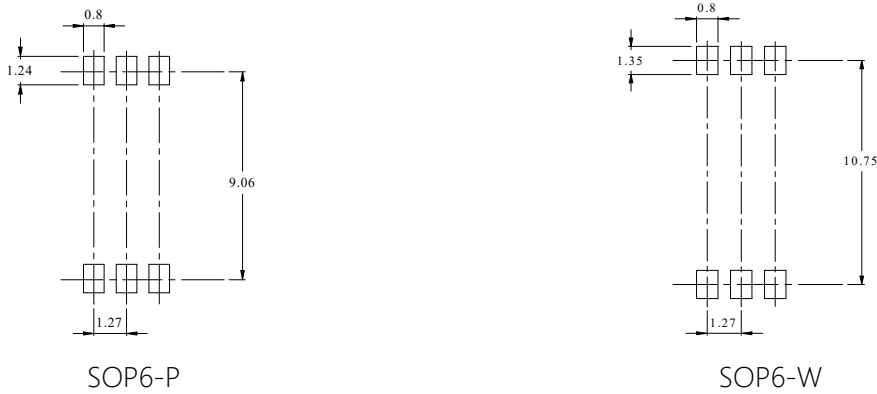

单位 Unit: mm

注意：上图为产品正视图。

Note: The picture above is the front view of the product.

回流焊温度曲线图 Solder Reflow Profile

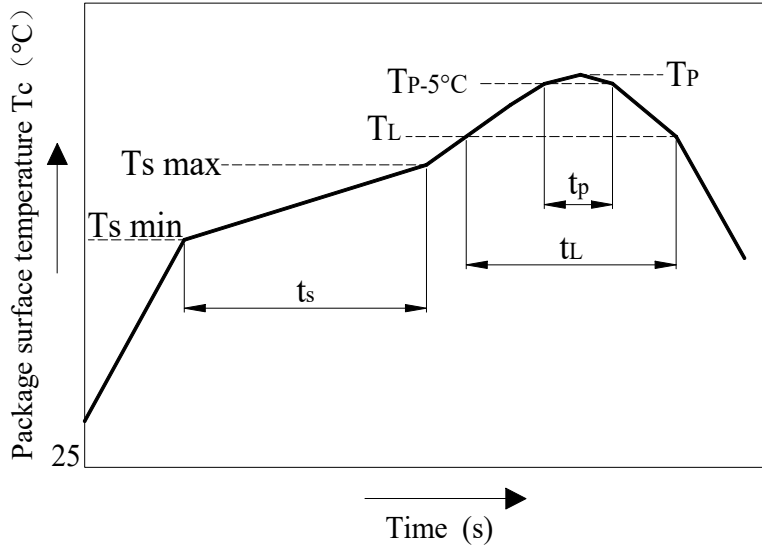

项目 Item	符号 Symbol	最小值 Min.	最大值 Max.	单位 Unit
预热温度 Preheat Temperature	T_s	150	200	°C
预热时间 Preheat Time	t_s	60	120	s
升温速率 Ramp-Up Rate (T_L to T_P)	-	-	3	°C/s
液相线温度 Liquidus Temperature	T_L	217		°C
时间高于 T_L Time Above T_L	t_L	60	150	s
峰值温度 Peak Temperature	T_P	-	260	°C
T_c 在 $(T_P - 5)$ 和 T_P 之间的时间 Time During Which T_c Is Between $(T_P - 5)$ and T_P	t_p	-	30	s
降温速率 Ramp-down Rate (T_P to T_L)	-	-	6	°C/s

注意：建议在所示的温度和时间条件下进行回流焊，最多不能超过三次。

Note: Reflow soldering is recommended at the temperatures and times shown, no more than three times.

波峰焊温度曲线图 Wave Soldering Profile

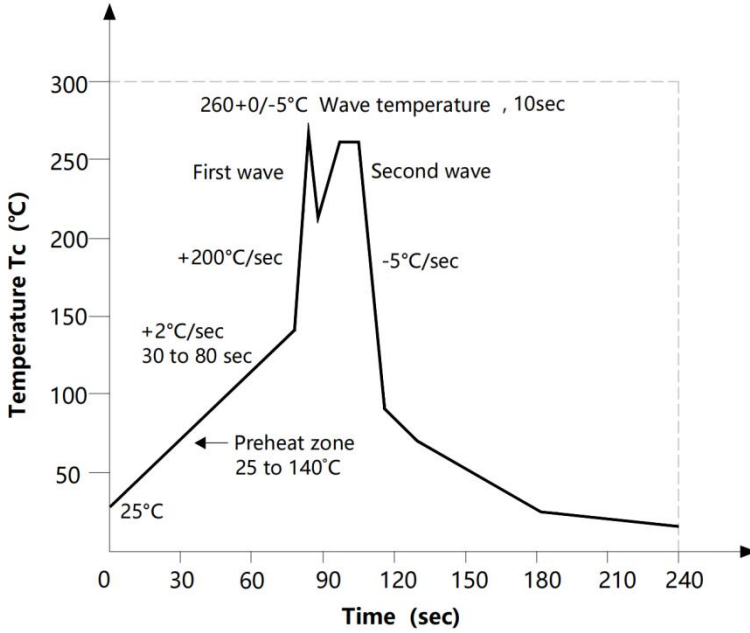

手工烙铁焊接 Soldering with hand soldering iron

- A. 手工烙铁焊仅用于产品返修或样品测试;
Hand soldering iron is only used for product rework or sample testing;
- B. 手工烙铁焊要求: 温度 $360^{\circ}\text{C} \pm 5^{\circ}\text{C}$, 时间 $\leq 3\text{s}$ 。
Manual soldering method Temperature: $360^{\circ}\text{C} \pm 5^{\circ}\text{C}$, within 3s.

包装 Packing

■ 汇总表 Summary table

封装形式	包装方式	盘数量	盒数量	箱数量	静电袋规格	盒规格	箱(双瓦楞)规格	备注
SOP6	卷盘 (φ330mm 蓝盘)	1000 只/盘	2 盘/盒	10 盒/箱	450*390*0.1mm	353*340*60 mm	650*375*365mm	首端空 50 个空格 末端空 100 个空格
Package Type	Packing Form	Quantity per Reel	Quantity per Box	Quantity per Carton	Antistatic Bag Specification	Box Specification	Carton Specification	Note
SOP6	Reel (φ330mm Blue)	1000 pcs/reel	2 reels/box	10 boxes/ctn	450*390*0.1mm	353*340*60 mm	650*375*365mm	Leave 50 Spaces at the beginning and 100 Spaces at the end

■ 编带包装 Tape & Reel

- 1) 每卷数量: 1000 只。
Qty/reel: 1000 pcs.
- 2) 每箱数量: 20000 只。
Qty/ctn: 20000 pcs.
- 3) 内包装: 每盒 2 盘。
Inner packing: 2 reels/box.
- 4) 示意图 Schematic:

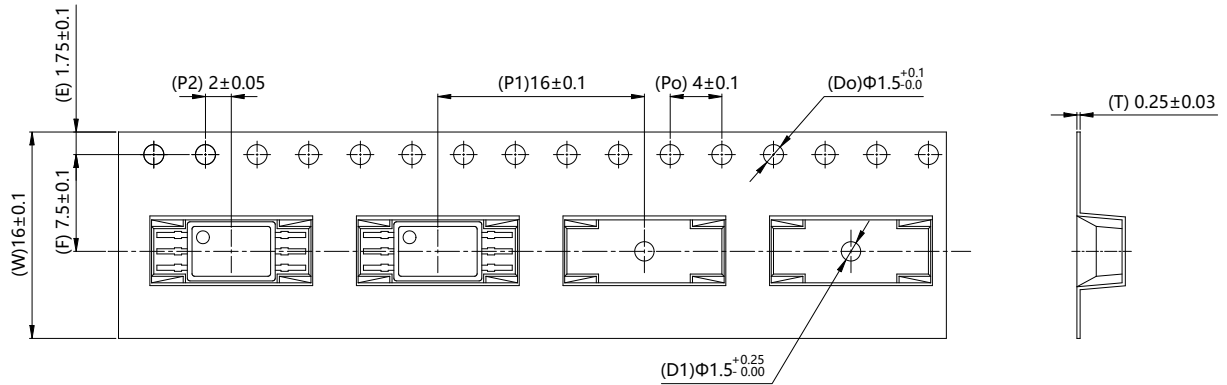

单位 Unit: mm

注意 Attention

- 群芯持续不断改进质量、可靠性、功能或设计，保留此文件更改的权利恕不另行通知。
QUNXIN continuously improve quality, reliability, function or design. We reserve the right to change this document without notice.
- 请遵守产品规格书使用，群芯不对使用时不符合产品规格书条件而导致的质量问题负责。
Please use in accordance with the product specification. QUNXIN is not responsible for the quality problems caused by non-compliance with the product specifications.
- 对于需要高可靠性或安全性的设备/装置需求，请联系我们的销售人员。
For equipment/devices where high reliability or safety is required, please contact our sales representatives.
- 当需要用于任何“特定”应用时，请咨询我们的销售人员。
When requiring a device for any “specific” application, please contact our sales in advice.
- 如对文件中表述的内容有疑问，欢迎联系我们。
If you have any questions about the contents of the document, please contact us.